



RX-3K RECEIVER INSTALLATION MANUAL

FOR KATO: RS-2, RSC-2, C44-9W,
ATLAS: U23B; BACHMANN: DOODLEBUG
LIFELIKE: 0-8-0
AND OTHERS — Just plug it in!

Basic installation (motor, power and sensor wiring)

NOTE: All receivers are shipped with the following configuration.

Primary channel = 01
Secondary channel = 01
Momentum = 0
Speed curve = 0
Headlight mode = 0

Please read the entire installation procedure before starting to install the receiver in a locomotive. If any of the steps are skipped or done wrong, there is the possibility of damaging the receiver.

RAIL-LYNX acknowledges that our receiver is more difficult to install than most command control systems, on the other hand, almost no modifications to the layout are required.

If after reading the instructions you feel uncomfortable about doing the mechanical and electrical work, you may want to consider one of the following options:

1. Have the installation done for you by a professional. RAIL-LYNX can supply you with the names of people who have installed large numbers of command control receivers and are interested in doing it for you for a modest fee.

2. If you do not want to do the installation yourself or have someone else do it for you, RAIL-LYNX will cheerfully allow you to return the units for a full refund of your purchase price. The only charge to you will be for shipping (this offer is made only if the units are returned exactly as they were shipped).

Assuming you have decided to do the installation, let's get on with it!

MECHANICAL

The receiver consists of two sections: The small printed circuit board (board from now on) and the small black photo-sensor (sensor from now on). The NMRA DCC socket of the loco board simply plugs into the plug on the receiver board, and the sensor is then located somewhere on the upper surface of the loco. The somewhere is the challenge!

1. Remove the body shell from the locomotive. The main portion of the shell lifts straight up from the running boards, leaving the running boards attached. We grab the shell at the short hood end and lift while pushing down on the running boards.

2. Now is the time to avoid a potential short circuit! Sometimes the brass motor contact tabs are bent up and over the top of the black plastic clip. Before installing the decoder bend the tabs down over the sides of the circuit board. This will avoid any potential short circuit of the decoder to the brass tabs.

3. If there is black plastic foam covering the pins on the bottom of the decoder remove and discard it.

4. Remove the two metal clips (already removed in the photo) from the 8 pin plug by pulling them straight up and out. Needle nose pliers work well here.

5. Insert the 8 pins on the bottom of the decoder into the socket on the locomotive. The "long" end of the decoder goes towards the left. **DO NOT DO THIS WITH THE LOCOMOTIVE ON THE TRACK.**

After the board has been installed the sensor mounting should be considered. This takes the most creativity. As stated above, it should be located on the upper surface to insure maximum exposure to the infrared signals sent by the transmitter. Another option is to mount in the cab windows, 1 sensor facing to either side of the track.

The sensor may be mounted on the upper surface of the loco by bending the leads 90 degrees and passing them through three holes drilled in the upper surface and then the three wires may be soldered to the sensor inside the loco.

One of the easiest sensor installations is to simply drill a 3/16" diameter hole in the top of the shell. Carefully counter sink the hole from the top and cover any exposed plastic (if it is a different color) with black paint. The sensor can then be mounted in one of two ways. One method is to glue the sensor on the inside of the shell with the dome centered in the hole and the leads connected as described below. Care should be taken that none of the sensor wires get tangled in the flywheel or other parts of the mechanism when the shell is put on.

Another, and recommended method, is to drill the same hole as above, but to mount the sensor on the mechanism of the loco, on top of a small piece of sponge rubber. The sensor will move up and down slightly, so when the shell is slipped onto the mechanism, the sensor will be held up against the bottom of the shell by the sponge rubber. The advantage of this mounting is that all of the wiring to the receiver can be anchored to the mechanism and the shell can be easily removed without having any wires dangling.

The three leads on the sensor may be bent 90 degrees without any damage, as long as they are held with pliers while bending to prevent stress on the plastic housing. Also, the sensor may be painted except for the domed part. The dome is where the infrared signal enters. Slight weathering has little effect on the sensor, but don't get carried away!

ELECTRICAL

There are three wires that have to be connected to the sensor from the receiver.

1. White: IR signal
2. Black: signal ground
3. Green: sensor power (+5V)

These sensor leads (white, black and green) must be connected next. Care should be taken not to apply the soldering iron to the leads too long (3 to 5 seconds max.) or the sensor may be damaged. Make sure that the green and white leads are not reversed (the black lead goes to the center lead, so that's tough to reverse). Please closely follow Figure 1 for the green and white connections and remember to picture how they look when viewed from the bottom, which is where the solder connections will be made. Note that the figure shows the sensor with the "dome" towards you. A piece of shrink tubing can be placed on the center pin to prevent any of the leads from shorting.

Make sure there are no pinched wires between the receiver and the frame or between the receiver and the connector pins.

To test the receiver, place the loco on a piece of test track. Connect the power supply or power pack to the track with the 10 ohm resistor (the one supplied with the receiver) connected in series with one of the leads (Figure 2). This resistor will most likely (but not positively) protect the receiver from a wiring error. Connect a multimeter set to read voltage, as shown in the figure.

Slowly advance the speed control on the power pack and observe the voltage reading on the meter. If the meter reads backwards, reverse the meter leads. Continue to increase the voltage until 12 volts is reached. If as the speed control is increased, the voltage does not read anything, or reads very little, most likely a short or miswire has occurred. Also a finger placed on the resistor can detect any temperature rise. The resistor will get hot if any thing is wrong! If the voltage does not increase and/or the resistor gets hot, quickly remove the power. After removing power recheck the wiring. Normally the resistor will prevent any damage to the receiver if something is wrong with the installation.

During this time the loco should not move, but sit patiently, waiting for a command from the hand-held transmitter. If it starts to move there is probably a miswire. Turn off the power and recheck the wiring.

If everything seems OK, turn on the RAIL-LYNX transmitter by flipping the toggle switch "up" to the on position. Set the top channel switch to "0" and the lower channel switch to "1". This selects channel 01, which is the primary channel that all receivers are initially loaded with

before shipment. Move the "FORWARD" switch to the right (HL), point the transmitter toward the loco, depress the right hand DIRECTION button and rotate the speed knob to about the eight or nine o'clock position.

The loco should begin to move or at least make a buzzing sound. If the loco just buzzes, increase the speed knob until it starts to move. To stop the loco depress the "STOP" button. After stopping the loco depress the left hand DIRECTION button. The loco should move in the opposite direction. If the loco behaves correctly the wiring is correct. Note: The loco will run slower than normal while on the test track.

On the first installation it may be desirable to make all connections temporary and operate the loco without the shell to confirm that the wiring is correct and understood. Please be very careful to make sure that none of the wiring or sensor leads touch the loco frame or the track as severe damage can result.

That's all there is to it... That wasn't all that bad was it

ADVANCED FEATURES AND INSTALLATION

SPEED CURVE

There are five speed curves stored in the receiver. Curves 0-3 are stored in program memory and cannot be changed. Curve 4 is stored in data memory and can be customer designed and loaded using SPEED-LYNX and any computer capable of running DOS.

The speed curve determines the speed of the loco vs the position of the speed knob.

Speed curve 0 is a linear straight line from 0 to 100% of track voltage.

Speed curve 1 is a linear straight line from 0 to 75% of track voltage.

Speed curve 2 is a linear straight line from 0 to 50% of track voltage.

Speed curve 3 is a linear straight line from 0 to 37% of track voltage

Speed curve 4 is a CUSTOM SPEED CURVE.

As shipped the receiver does not have a speed curve 4, it should not be selected.

It can be changed using the SPEED-LYNX software running under DOS, and either the loader module, or any repeater. Any of the 126 speed values may be assigned to any of the 32 knob positions to produce any type of curve desired. See the SPEED-LYNX manual.

SPEED CURVE SELECTION

To select one of the speed curves, set the loco's primary channel on the channel switches and set the speed knob in position 0 (full stop), 1, 2, 3, or 4. While holding the "SHIFT" button down, depress the hidden button on the bottom of the XMTR. This will select the desired speed curve.

CAUTION: this command is an offshoot of the primary channel command and will be accepted by any loco equipped with an older RX-1 receiver seeing the message. It should normally be used only during installation on the bench, or be sure you prevent any other locos in the area from accidentally accepting the command.

SPEED OFFSET

This is used to correct for a loco that doesn't start until the speed is increased to a fairly high value. This command essentially adds several (up to 7) clicks to the speed knob's position. Any number over 7 will be interpreted as 7.

For example, suppose a loco does not start to move until the speed knob has reached 6 clicks. A reasonable correction would be to add 4 clicks of positive speed offset. To do this, set the loco's primary channel on the channel switches, and advance the speed knob 4 clicks above 0. Depress the hidden button on

the bottom of the XMTR. This will load an offset of 4 into the loco. Now the loco should start to move after only 2 clicks.

CAUTION: This command is an offshoot of the primary channel command and will be accepted by any loco seeing the message. It should normally be used only during installation on the bench, or be sure you prevent any other locos in the area from accidentally accepting the command.

HEADLIGHTS

Kato supplies yellow LED's for headlights. The appearance is not the best. You may want to change them out for incandescent lamps or white LED's, which look much better.

If you decide to change the bulbs, we recommend Miniaturionics #18-712-10 (12V), or #18-014 (14V) or Chicago Miniature white LED's (Digikey part number CMD204UWC, phone 800-344-4539). If you use the LED's a 1K1/4 watt resistor must be installed in series with each LED.

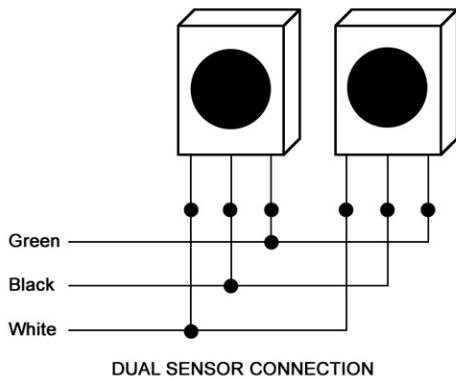

Figure 1

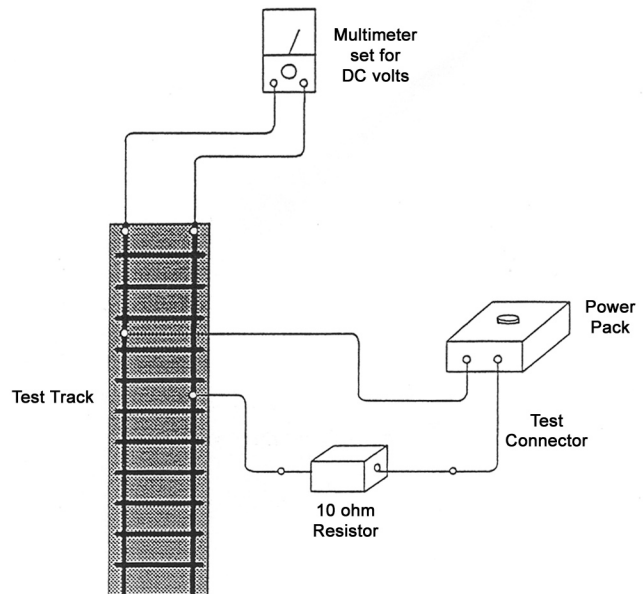

Figure 2

RAIL-LYNX

1 Cottontail Lane, Columbia, NJ 07832

Tel.: 908-496-4686; Fax: 908-496-4074; E-mail: shawn@rail-lynx.com

Website: www.rail-lynx.com; User Group: <http://groups.yahoo.com/group/rail-lynx>