



RX-3T RECEIVER INSTALLATION MANUAL

FOR ATLAS ALCO S1, S2, S3, & S4 LOCOMOTIVES

Basic installation (motor, power and sensor wiring)

NOTE: All receivers are shipped with the following configuration.

Primary channel = 01 Speed curve = 0
Secondary channel = 01 Headlight mode = 0
Momentum = 0

Please read the entire installation procedure before starting to install the receiver in a locomotive. If any of the steps are skipped or done wrong, there is the possibility of damaging the receiver.

RAIL-LYNX acknowledges that our receiver is more difficult to install than most command control systems, on the other hand, almost no modifications to the layout are required.

If after reading the instructions you feel uncomfortable about doing the mechanical and electrical work, you may want to consider one of the following options:

Have the installation done for you by a professional. **RAIL-LYNX** can supply you with the names of people who have installed large numbers of command control receivers and are interested in doing it for you for a modest fee.

If you do not want to do the installation yourself or have someone else do it for you, **RAIL-LYNX** will cheerfully allow you to return the units for a full refund of your purchase price. The only charge to you will be for shipping (this offer is made only if the units are returned exactly as they were shipped).

Assuming you have decided to do the installation, let's get on with it!

MECHANICAL

1. Remove the body shell from the locomotive. The cab comes off first followed by the main body.
2. Unsolder the 4 wires from the existing locomotive circuit board.
3. Remove the screw holding the pcboard and discard the board.
4. Lift the weight off of the motor and place it to the side.
5. **IMPORTANT** – Place a mark on the motor denoting which way is up.

6. Unscrew the motor from the locomotive frame. There is one 2mm screw holding the motor to the frame on the bottom of the loco. Hold the motor in place while removing the screw so that it doesn't fall out.
7. Carefully lift the motor from the frame (the drive shafts will fall out, be careful not to lose them)
8. Cut the supplied Kapton™ tape to 1.5" long.
9. Cover the **bottom** of the motor with the tape. Wrap the excess up the sides and ends of the motor.
10. Use a sharp knife or other tool to pierce a small hole in the tape to open the screw hole on the bottom of the motor.
11. Re-install the motor into the frame, do not forget the two drive shafts (tweezers help a lot)
12. Use the **plastic 2mm screw** provided with the receiver to fasten the motor to the frame.
13. Replace the weight on the motor, the open ended notch in the weight is towards the front and the open holes should expose the top motor brush.
14. Install the receiver with the "10122 REV A" side up. If you want to connect a rear headlight please see the section on HEADLIGHTS.
15. Solder the truck leads to the 4 pads on the corners of the skinny section of the board.
16. Ensure the board is properly seated in the shallow channel of the upper weight.

After the board has been installed the sensor mounting should be considered. A sensor mounting board has been included with your receiver. It is up to you to decide how you would like to mount the sensor board. On my installs I put the board just below the cab windows, copper side up. Then the sensors leads double back on themselves so that the dome winds up centered in the rear most cab windows on either side. Make sure to put a piece of electrical tape on the underside of the RX-3T to insulate it from the sensors. If you decide you would prefer to mount just a single sensor on the top of the loco the sensor board should still be connected to the receiver as it will effect operation without it on this

particular receiver as the capacitor is mounted to the sensor board.

ELECTRICAL

The sensors must be placed in the sensor board correctly to work. If the sensor comes out the side with the copper, the dome (before bending) would be facing the center of the board. If the sensor comes out the side without copper, the dome would be facing to the outside. The sensor board was designed to give a lot of flexibility and not to be a perfect mounting position. Please feel free to adjust the leads as necessary to make the sensor dome be where you need it. Remember to strain relieve the sensor leads with pliers if you are bending the leads close to the body of the device.

There are three wires that have to be connected to the sensor board from the receiver.

1. White: IR signal
2. Black: signal ground
3. Green: sensor power (+5V)

The holes are marked with a W, B, and G. The marking is to the right of the hole, on some it is a little ambiguous but if you remember the marking is to the right you will be OK.

Make sure there are no pinched wires between the receiver and the frame or between the receiver and the connector pins..

To test the receiver, place the loco on a piece of test track. Connect the power supply or power pack to the track with a 10 ohm 5W resistor (please ask if you need 1) connected in series with one of the leads (see Fig. 2). This resistor will most likely (but not positively) protect the receiver from a wiring error. Connect a multimeter set to read voltage, as shown in the figure.

Slowly advance the speed control on the power pack and observe the voltage reading on the meter. If the meter reads backwards, reverse the meter leads. Continue to increase the voltage until 12 volts is reached. If as the speed control is increased, the voltage does not read anything, or reads very little, most likely a short or miswire has occurred. Also a finger placed on the resistor can detect any temperature rise. The resistor will get hot if any thing is wrong! If the voltage does not increase and/or the resistor gets hot, quickly remove the power. After removing power recheck the wiring. Normally the resistor will prevent any damage to the receiver if something is wrong with the installation.

During this time the loco should not move, but sit patiently, waiting for a command from the hand-held transmitter. If it starts to move there is probably a miswire. Turn off the power and recheck the wiring.

If everything seems OK, turn on the RAIL-LYNX transmitter by flipping the toggle switch "up" to the on position. Set the top channel switch to "0" and the lower channel switch to "1". This selects channel 01, which is the primary channel that all receivers are initially loaded with before shipment. Move the "FORWARD" switch to the right (HL), point the transmitter toward the loco, depress the right hand DIRECTION button and rotate the speed knob to about the eight or nine o'clock position.

The loco should begin to move or at least make a buzzing sound. If the loco just buzzes, increase the speed knob until it starts to move. To stop the loco depress the "STOP" button. After stopping the loco depress the left hand DIRECTION button. The loco should move in the opposite direction. If the loco behaves correctly the wiring is correct. Note: The loco will run slower than normal while on the test track.

On the first installation it may be desirable to make all connections temporary and operate the loco without the shell to confirm that the wiring is correct and understood. Please be very careful to make sure that none of the wiring or sensor leads touch the loco frame or the track as severe damage can result.

That's all there is to it.. that wasn't all that bad, was it?

ADVANCED FEATURES AND INSTALLATION

SPEED CURVE

There are five speed curves stored in the receiver. Curves 0-3 are stored in program memory and cannot be changed. Curve 4 is stored in data memory and can be customer designed and loaded using SPEED-LYNX and any computer capable of running DOS.

The speed curve determines the speed of the loco vs the position of the speed knob.

Speed curve 0 is a linear straight line from 0 to 100% of track voltage.

Speed curve 1 is a linear straight line from 0 to 75% of track voltage.

Speed curve 2 is a linear straight line from 0 to 50% of track voltage.

Speed curve 3 is a linear straight line from 0 to 37% of track voltage

Speed curve 4 is a CUSTOM SPEED CURVE.

As shipped the receiver does not have a speed curve 4, it should not be selected.

If can be changed using the SPEED-LYNX software running under DOS, and either the loader module, or any repeater. Any of the 126 speed values may be assigned to any of the 32 knob positions to produce any type of curve desired. See the SPEED-LYNX manual.

SPEED CURVE SELECTION

To select one of the speed curves, set the loco's primary channel on the channel switches and set the speed knob in position 0 (full stop), 1, 2, 3, or 4. While holding the "SHIFT" button down, depress the hidden button the bottom of the XMTR. This will select the desired speed curve.

CAUTION: This command is an offshoot of the primary channel command and will be accepted by any loco equipped with an older RX-1 receiver seeing the message. It should normally be used only during installation on the bench, or be sure you prevent any other locos in the area from accidentally accepting the command.

SPEED OFFSET

This is used to correct for a loco that doesn't start until the speed is increased to a fairly high value. This command essentially adds several (up to 7) clicks to the speed knob's position. Any number over 7 will be interpreted as 7.

For example, suppose a loco does not start to move until the speed knob has reached 6 clicks. A reasonable correction would be to add 4 clicks of positive speed offset. To do this, set the loco's primary channel on the channel switches, and advance the speed knob 4 clicks above 0. Depress the hidden button on the bottom of the XMTR. This will load an offset of 4 into the loco. Now the loco should start to move after only 2 clicks.

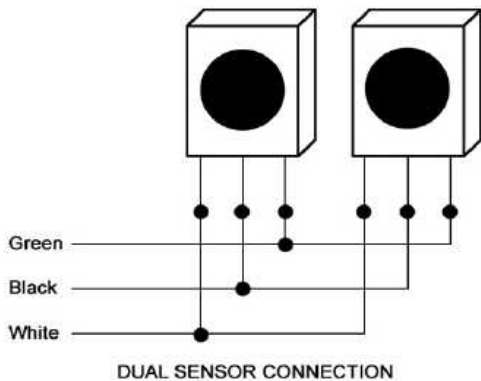

Figure 1

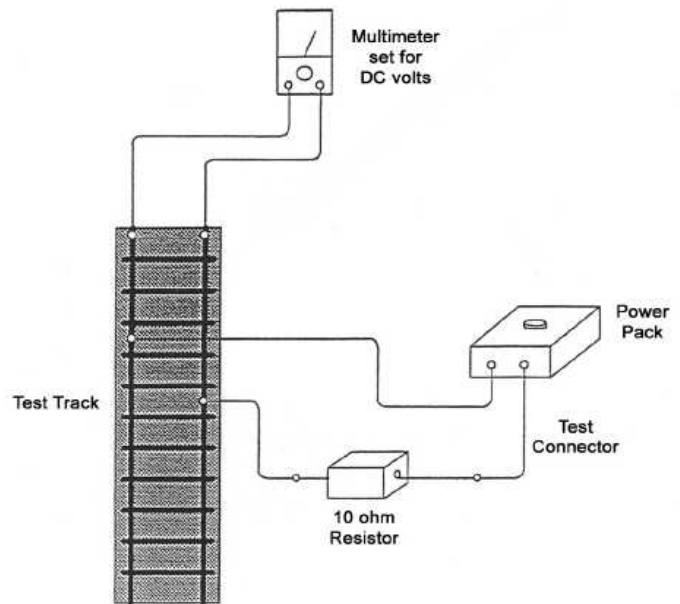

Figure 2

CAUTION: This command is an offshoot of the primary channel command and will be accepted by any loco seeing the message. It should normally be used only during installation on the bench, or be sure you prevent any other locos in the area from accidentally accepting the command.

HEADLIGHTS

The headlight is already attached to the receiver. I do not suggest trying to use a rear light as the cab is already very packed and putting a light source in there can adversely effect the IR reception. If you must have a rear light please contact me for further instructions.

RAIL-LYNX

1 Cottontail Lane, Columbia, NJ 07832

Tel.: 908-496-4686; Fax: 908-496-4074; E-mail: shawn@rail-lynx.com

Website: www.rail-lynx.com; User Group: <http://groups.yahoo.com/group/rail-lynx>